

TECHNICAL DATA SHEET

- 4in/2out Mic/Line Mixer.
- Alarm & Paging Inputs.
- PL remote compatibility with additional analogue remote inputs.

Primary and Secondary Mic Modes: Perfect for controlling hierarchal microphone feeds such as simple paging announcements.

- Emergency Mic Mode: For use with 3rd party systems in emergency situations. Mutes all inputs except MIC 1 on alarm contact closure.
- Juke Box Mode: Provides a priority line input to the system for pre-recorded announcements or programme material such as Sports channels.

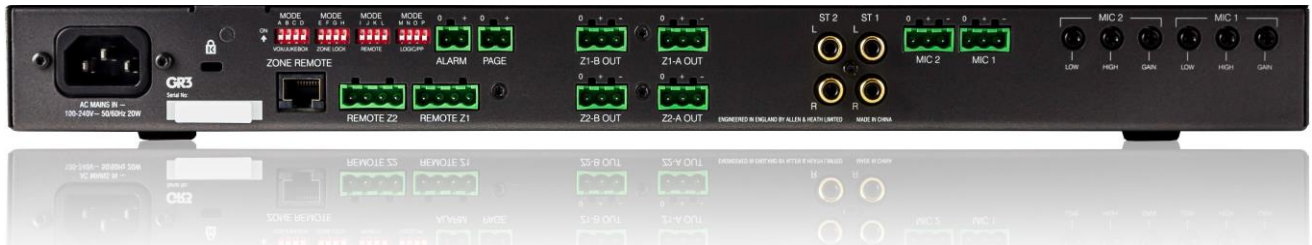

GR3

The mixer shall be a 1U rack-mountable analogue mixer with 4 inputs and 2 Zone outputs.

Physical

The unit shall have two balanced microphone inputs on pluggable terminal blocks. Each mic input shall have independent gain control on rear mounted pots and have a +50dB gain and global Hi-Level LED indication if any pre level signal is greater than 14dBu. In addition microphone "1" shall be made switchable to a front mounted XLR connector via a front mounted selection switch.

There shall be independent control of High and Low frequency band EQ via pots mounted on the rear of the chassis and a 200Hz HP filter shall be employed via rear mount dip-switches.

There shall be two stereo unbalanced line level inputs on RCA connectors. Each stereo input shall have an independent level pot with +5dB trim and global Hi-Level LED indication if any pre level signal is greater than 14dBu. An additional 10dB shall be available for low level sources via a PCB jumper. There shall be a priority line level input which will override all other line level sources, however, there shall be the ability to disable this function via a dip-switch.

The unit shall have two impedance balanced stereo zone outputs on pluggable terminal blocks. Each zone shall have input source selection and variable mic and music level pots. There shall be independent control of High and Low frequency band EQ via front mounted pots and a 3 LED stereo level meter. There shall be internal jumpers to mono zones 1 & 2.

The unit shall accept remote control inputs via two rear mounted 4-wire pluggable terminal blocks. Each connector will allow analogue control of music source and level via a 0 - 10v control signal. An additional RJ45 connector shall be present to accept off the shelf wall mounted controllers with a maximum of two controllers connected in daisy chain configuration. Remote control shall be enabled via dip switch.

There shall be an alarm contact closure input on a pluggable screw terminal connector. The input shall be Normally Open (NO) and reversed to Normally Closed (NC) via DIP switch.

Features

The unit shall have the following features:

Primary mic mode: When audio sensed on MIC1 channel and/or PAGE contact closure is sensed then music is faded to pre-set level and MIC2 muted for the duration of the announcement. MIC1 zone select LEDs flash slowly when in priority mic mode.

Secondary mic mode: When audio is sensed on MIC2 then music is faded to pre-set level for the duration of the announcement. MIC2 zone select LEDs flash slowly when in secondary mic mode.

Emergency mic mode: When alarm contact is activated all zone feeds are muted and MIC 1 is fed direct to all zones. All select LEDs except mic1 LED are switched off for the duration. MIC1 LED will flash quickly.

Juke box mode: When music sensed on ST2, fade down current music feed and fade up ST2. When ST2 silent for pre-set period, fade down ST2 and resume previous music feed. Mic volume not affected.

Music fade: Option to select next music feed and then unit will fade between sources after short delay.

Zone lock: Allows select buttons to be disabled for a particular zone. LED corresponding to the button locked will be turned off.

General

It shall have a built in power supply accepting AC mains voltages of 100-240V, 50/60 Hz, 20W max via an earthed 3-pin IEC C6 male connector mounted on the rear chassis.

A switch shall be provided on the front chassis to isolate the mixer from the incoming mains supply.

Recommended operating temperature for the mixer shall be 5 to 35 degrees Celsius.

The unit shall be the Allen & Heath GR3.

BLOCK DIAGRAM

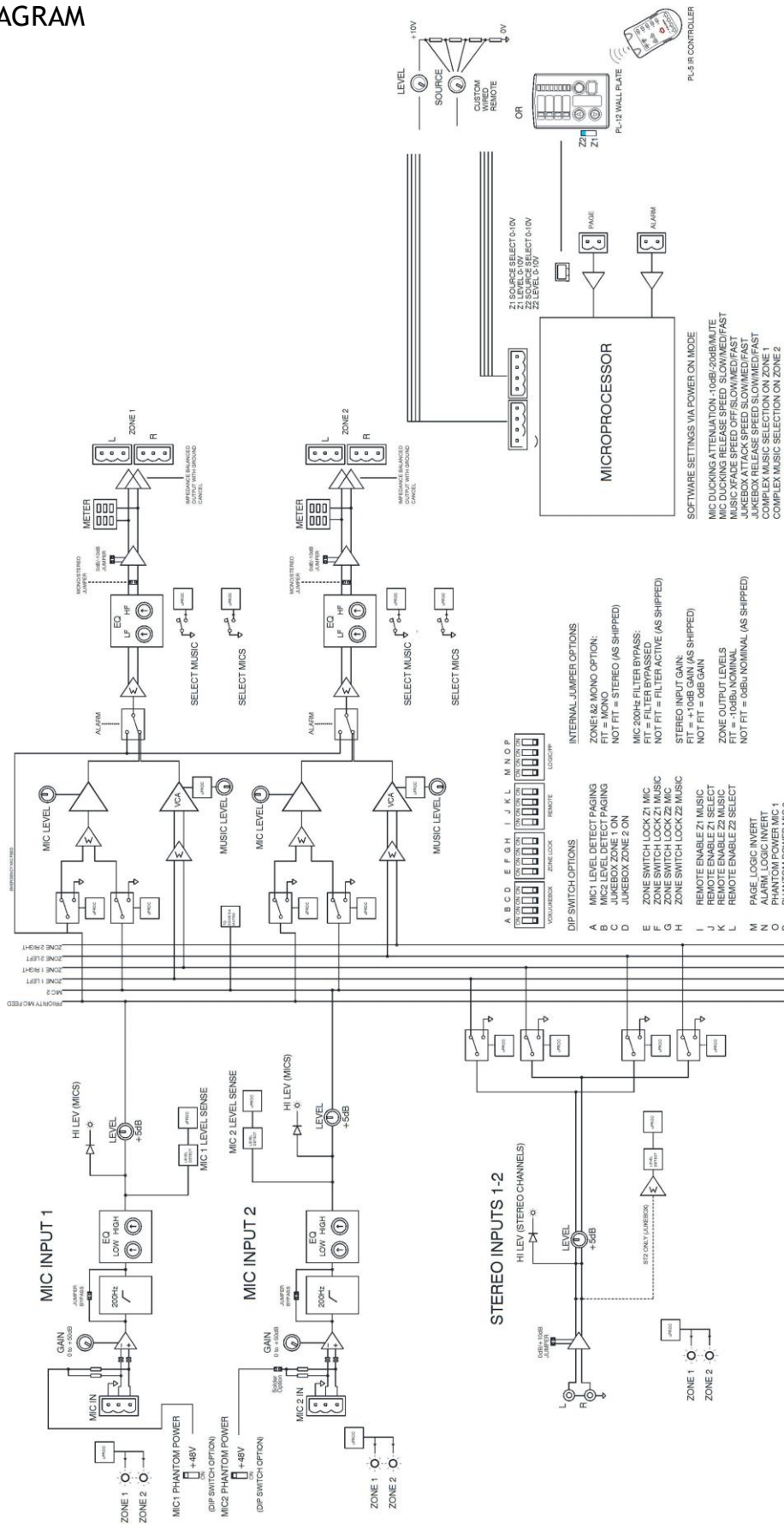

Mic Input Sensitivity (Gain = Min)	0dBu
Mic Input Sensitivity (Gain = Max)	-50dBu
Mic Level control (Max)	+5dB
Mic Level control (Min)	-80dB
Mic HPF -3dB	320Hz (TBC)
Mic EQ LF	+/- 15dB fc = 80Hz
Mic EQ HF	+/- 15dB fc = 8kHz
Mic Frequency Response	20Hz - 20kHz +/- 1dB
Mic THD+n @0dBu in 1kHz	0.004% 22-22kHz
Mic THD+n @-30dBu in 30dB gain 1kHz	0.005% 22-22kHz
Mic Hi Level warning LED (Unity gain)	+18dBu
Clip level (Unity gain)	+21dBu
ST Input Sensitivity (Gain link OFF)	0dBu
ST Input Sensitivity (Gain Link ON)	-10dBu
ST Level control (Max)	+6dB
ST Level control (Min)	-76dB
ST Frequency response 20Hz	20Hz - 20kHz +/- 0.5dB
ST THD+n @-10dBu in 1kHz	0.015% 22-22kHz
ST THD+n @0dBu in 1kHz	0.035% 22-22kHz
Crosstalk from unselected channel	-75dB @ 1kHz
Main Zone Level control (Max)	0dB
Main Zone Level control (Min)	-74dB
Main Zone Hi Lev LED (Unity gain)	+18dBu
Main Zone EQ LF	+/- 15dB fc = 80Hz
Main Zone EQ HF	+/- 15dB fc 8kHz
Main Zone Clip level (Unity gain)	+21dBu
Noise:	
ST Input to Main Zone output (Unity)	-90dBu 22-22kHz
Mic Input routed at Min gain as well	-88dBu 22-22kHz
Mic Input routed at Max gain	-77dBu 22-22kHz (150R source)
Power consumption:	
GR3 unit (no remote attached)	15W
Weights & Dimensions:	
Height	48mm (1.9")
Length	242mm (9.5")
Width	438mm (17.2")
Weight	3.4kg (7.5lbs)

