

AMX-812

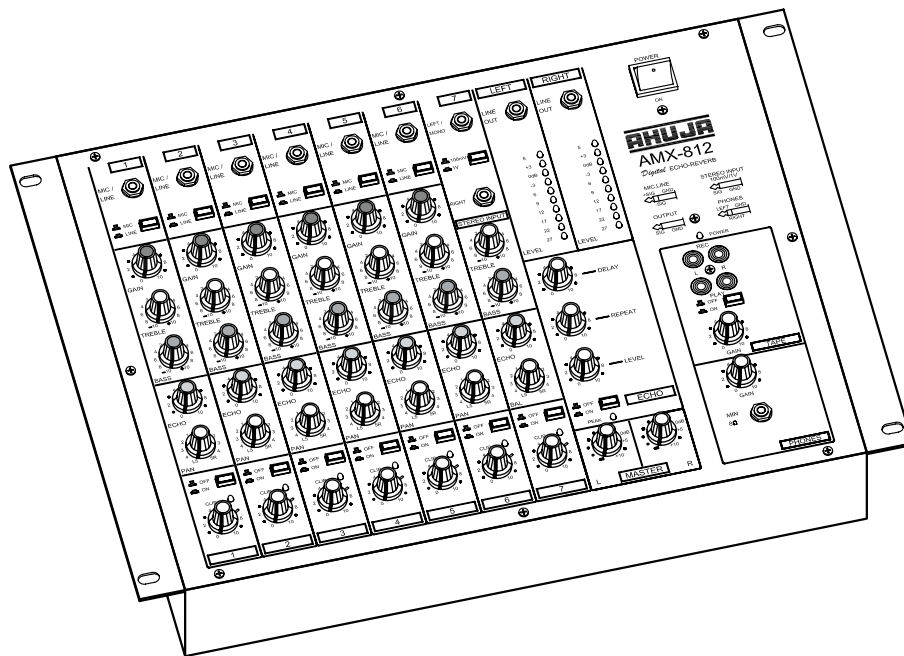

- ◆ Thank you for purchasing the AHUJA PA Audio Mixer.
- ◆ Please read this manual thoroughly before making connections and turning on the power. Following the instructions in this manual will enable you to obtain optimum performance from your new AHUJA PA Audio Mixer.
- ◆ Please retain this manual for future reference.

• Safety Instructions

Read the Instructions: Please read all the instructions in this section carefully before installation or use of the product. All the safety instructions must be followed.

Retain the Instructions: Please retain this Instruction Manual for future reference.



This symbol, wherever it appears, alerts you to the presence of uninsulated hazardous voltage that may be sufficient to constitute a risk of electric shock. External wiring to any terminal marked with this symbol must be done by a trained and instructed person only.



This symbol, wherever it appears adjacent to a component, alerts you that the concerned component can only be replaced by another of the exact same specifications.

WARNING

- To reduce the risk of electric shock, do not remove the top cover. No user serviceable parts inside. Refer all servicing to qualified personnel only.

CAUTIONS

Water & Moisture: To reduce the risk of fire or electrical shock, do not expose this set to rain or moisture. Do not use this set near water or in a wet location. Do not keep any object filled with liquid, such as a vase, on top of this set. Do not insert or remove the AC mains plug with wet hands.

Power Source: The voltage & frequency of the AC mains supply, and the voltage of the external battery, (if applicable) to which this set can be connected, is marked on the rear panel of the set. Do not connect this set to any power source other than those specified on the rear panel.

Power Cord Protection: Do not cut, kink, damage or modify the AC power cord supplied with this set. Keep the AC power cord away from heaters and harmful chemicals. Do not keep any heavy object on the power cord.

Operation on Generator: When operating this set on a generator, make sure the set is switched off till the generator voltage has stabilized.

Stability: This set must be kept in a stable and flat horizontal position, and never in a tilted position. Do not place this set on an unstable stand, tripod, bracket or mount. Do not use attachments which are not supplied or explicitly recommended by the manufacturer.

Earthing: This set must be earthed properly before use. A wire from the Earth terminal on the rear panel must be connected to electrical earth.

Cleaning: Disconnect this equipment from the AC mains and external battery before cleaning. Clean with a damp cloth, but do not allow any liquid to enter the set. Do not clean with liquids or aerosols.

• Table of Contents

Contents	Page No.
• Introduction	4
• Top and Rear Panel	5
• The Input Section	6
• The Stereo Section	7
• The Output Section	8
• The Echo Section	9
• The Tape Section.	10
• The Headphone Section	10
• Power Supply Section.	11
• Typical Applications	12
• Operation	14
• Plugs Wiring	15
• Specifications	16

• Introduction

The AMX-812 is 8 CHANNEL PA Mixer with Echo, Reverb & Chorus Effects. The 6 Inputs, Mic / Line, have individual Gain controls, Bass & Treble controls, Echo controls, Pan controls, Channel On/Off switches, Channel level controls. The additional Stereo channel has dual Line sensitivity, Bass & Treble controls, Echo control, Balance control, Channel On/Off switch, Channel level control. It has a separate TAPE SECTION for Recording and Playback.

- 6 Mic inputs for balanced/unbalanced low impedance microphones.
- 6 Line inputs, balanced/unbalanced for connecting CD/Cassette Players, Keyboards etc.
- Gain controls for each input channel.
- Bass & Treble controls for each input channel.
- Echo mix level controls for each input channel.
- Pan controls for each input channel for adjusting the routing of the input channel signal to the Left or Right outputs.
- On/Off switch for each input channel.
- Level control is provided for each input channel.
- DIGITAL signal processing used to process Echo, Reverb and Chorus effects.
- Echo section for Echo , Reverb and Chorus effects through Repeat, Delay and Level controls. Echo On/Off switch available.
- An independent additional Stereo input channel with two sensitivities and Bass, Treble, Echo, Balance controls provided. Left channel of Stereo input can be used as a Mono input channel.
- A separate Tape Section for connecting a Cassette Recorder for recording /playback.
- Master level controls for Left and Right output .
- Unbalanced Line Outputs provided for the Left and Right channels.
- 10 LED arrays for indicating output levels.
- Headphone stereo output with gain control.
- AC Mains / 24V DC (Car Battery) Operation.

• Top and Rear Panel

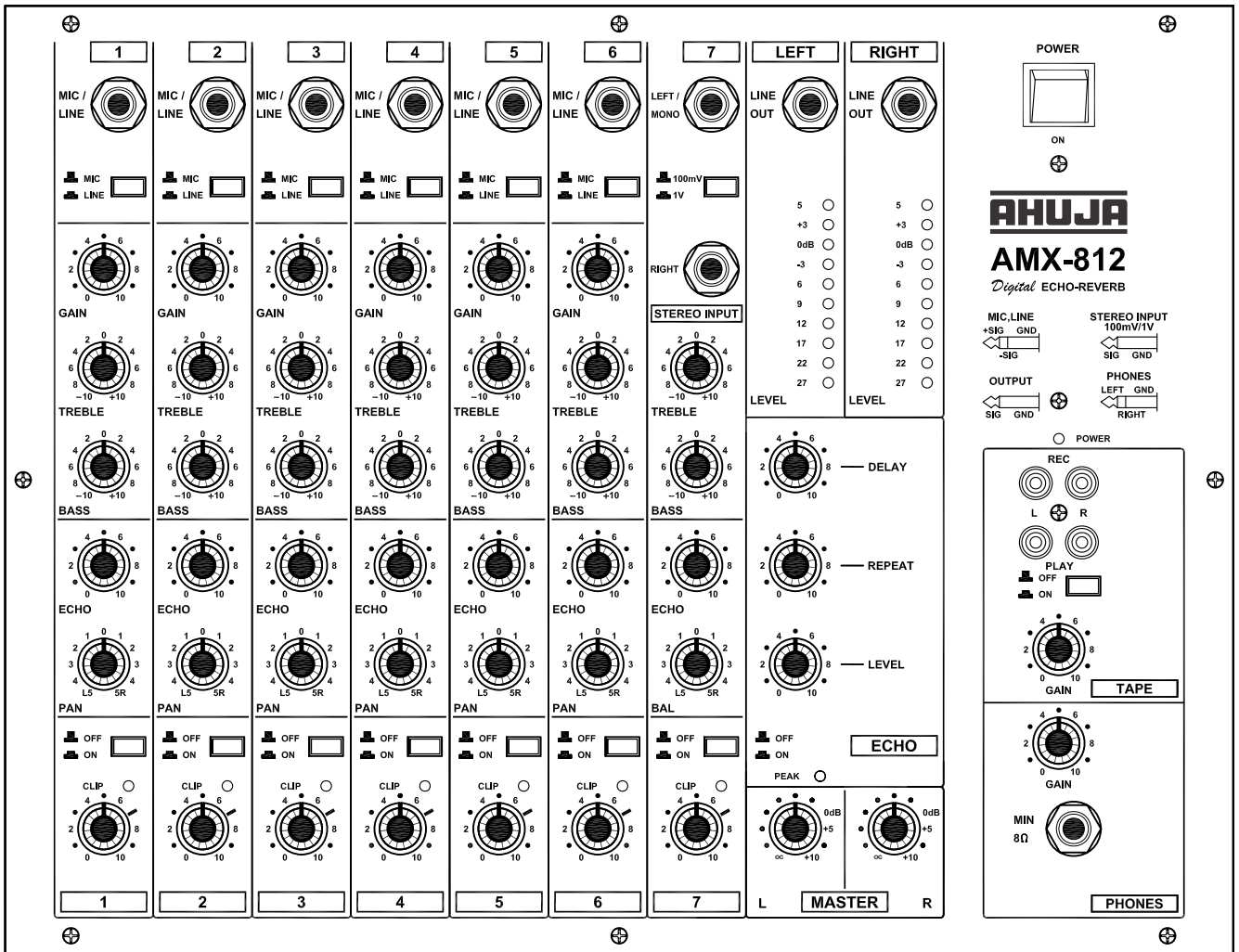

TOP PANEL

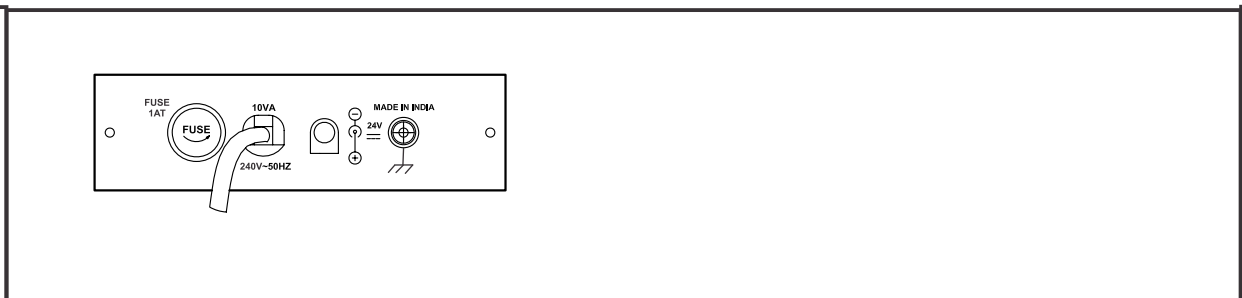

REAR PANEL

• The Input Section

1. MIC/LINE INPUT

Input through balanced 1/4" phone jack for accepting both balanced and unbalanced signals (plugs). For low impedance microphones, 200 ohms to 1K ohms or sources such as Cassette Players, CD Players, Keyboards, Drum Machines etc.

Wiring: Tip Hot (+ve phase)
 Ring Cold (-ve phase)
 Sleeve Ground

2. MIC/LINE SWITCH

This switch is used for selecting the type of input source connected to input channel.

3. GAIN CONTROL

The gain control sets the signal level for the Mic / Line input. The Clip LED indicates the Max. level of gain control settings.

4. TREBLE CONTROL

The Treble control gives 12 dB of boost or cut at 10 kHz. High boost livens up a "dead" room acoustics imbalance.

5. BASS CONTROL

The Bass control gives 12 dB of boost or cut at 100Hz. Low cut avoids boominess in some rooms.

6. ECHO CONTROL

Echo level control is for deciding the level of that channel in the final Echo Mix. This is post-Equalizer (Bass & Treble) and post-Channel control. Therefore, the level will be affected by the setting of the Channel control.

7. PAN CONTROL

This control routes the channel to either Left or Right Output . Centering the control positions the signal equally in both the outputs.

8. ON/OFF SWITCH

This switch is provided for switching OFF of the input channel without disturbing the control settings.

9. CLIP

The Clip LED lights up when the signal in the channel is approaching overload (clip) level. Setting this correctly ensures maximum "Signal to Noise ratio", that is the best signal level with the minimum amount of background noise. It should be set just before the overload level. Occasional flashing of the LED during loud sounds is OK.

10. CHANNEL CONTROL

The channel 'rotary' control determines the output level of the channel in the overall mix.

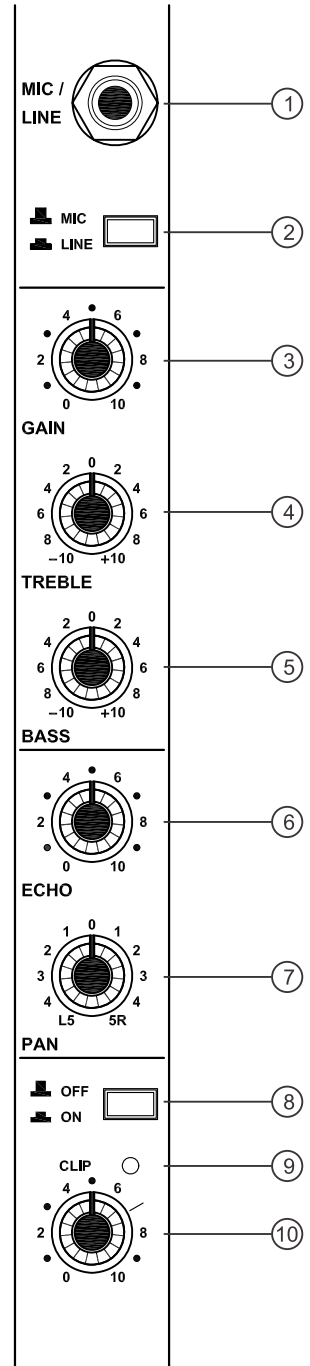

• The Stereo Section

1. LEFT/MONO INPUT

Input through unbalanced 1/4" phone jack for accepting signals of 100mV or 1V levels. For sources such as Cassette Players, CD Players, Effects Units etc.

Wiring: Tip Signal
 Sleeve Ground

2. 100mV/1V SWITCH

This switch is used for selecting signal sensitivity (100mV or 1V) suitable for type of input source connected to LEFT/MONO & RIGHT inputs.

3. RIGHT INPUT

Input through unbalanced 1/4" phone jack for accepting signals of 100mV or 1V levels. For sources such as Cassette Players, CD Players, Effects Units etc.

Wiring: Tip Signal
 Sleeve Ground

4. TREBLE CONTROL

The Treble control gives 12 dB of boost or cut at 10 kHz. High boost livens up a "dead" room acoustics imbalance.

5. BASS CONTROL

The Bass control gives 12 dB of boost or cut at 100Hz. Low cut avoids boominess in some rooms.

6. ECHO CONTROL

Echo level control is for deciding the level of that channel in the final Echo Mix. This is post-Equalizer (Bass & Treble) and post-Channel control. Therefore, the level will be affected by the setting of the Channel control.

7. BALANCE CONTROL

This control routes the channel to either Left or Right Output . Centering the control positions the signal equally in both the outputs.

8. ON/OFF SWITCH

This switch is provided for switching OFF of the input channel without disturbing the control settings.

9. CLIP

The Clip LED lights up when the signal in the channel is approaching overload (clip) level. Setting this correctly ensures maximum "Signal to Noise ratio", that is the best signal level with the minimum amount of background noise. It should be set just before the overload level. Occasional flashing of the LED during loud sounds is OK.

10. CHANNEL CONTROL

The channel 'rotary' control determines the output level of the channel in the overall mix.

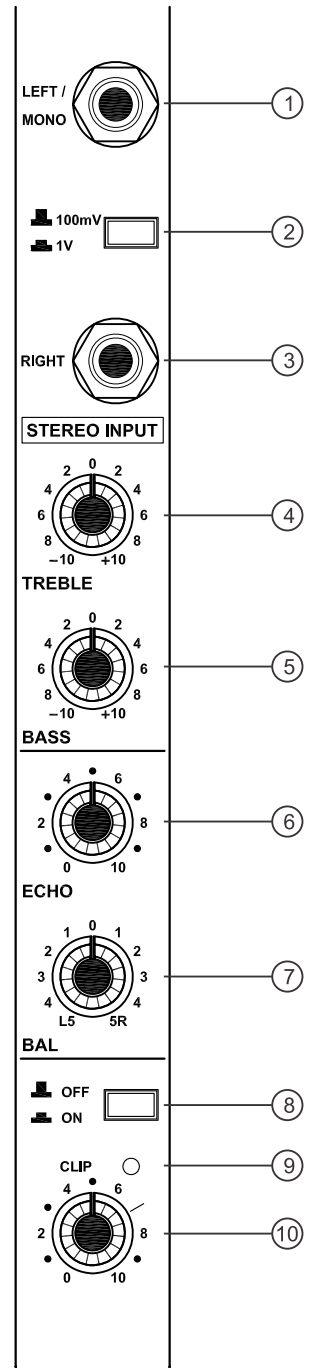

• The Output Section

1. LINE OUTPUT

Unbalanced Line Outputs have been provided for the Left and Right channels through 1/4" phone jacks. These are for connecting to the LINE INPUT of the Power Amplifier. The Line Output levels (0mV to 775mV) can be adjusted by Master Level Controls.

Wiring: Tip Signal
 Sleeve Ground

2. LED BARGRAPH

There are 2 colour , 10 segment LED Arrays which display the Left & Right output levels. The 0dB LEDs correspond to 775mV Line output.

3. LEFT/RIGHT MASTER CONTROLS

The Left & Right controls are the master output level controls. These determine the level of all the signals (mix) sent by the Channel controls and Tape Playback, to the L/R Line Output jacks.

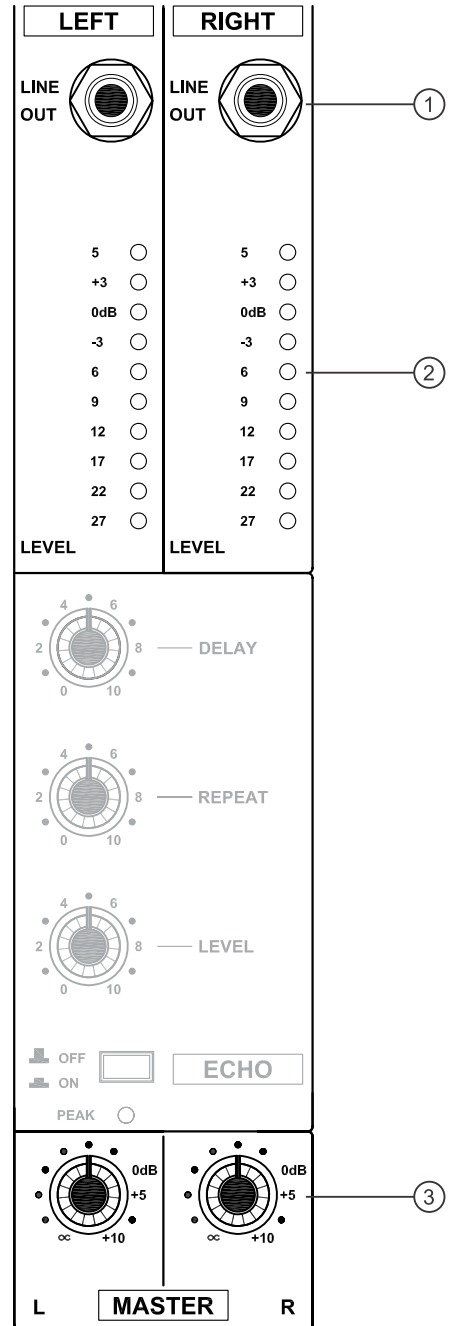

• The Echo Section

The ECHO section provides ECHO, REVERB and CHORUS effects to all the Input channels. These Effects can be obtained by different settings of Delay Control, Repeat Control and Level Control. The Echo Section can be switched Off through a On/Off switch.

1. **DELAY Control**
For setting the time between ECHO repetitions.
2. **REPEAT Control**
This controls the number of repetitions of ECHO. The higher the setting, the more repetitions.
3. **LEVEL Control**
For setting the ECHO level.
4. **ECHO ON/OFF Switch**
When this switch is in OFF position, AMX-812 operates as Mixer only without Echo/Effects on all the inputs irrespective of the settings of the Echo controls of individual channels.
5. **PEAK LED**
The Echo Controls & Level Controls of each channel and Level Control of Echo Section should be set at a level just below the flickering level of this Peak LED. This LED is for optimizing the Inputs and Echo levels. The settings of the Channel Controls & Master Controls have no effect on this LED.

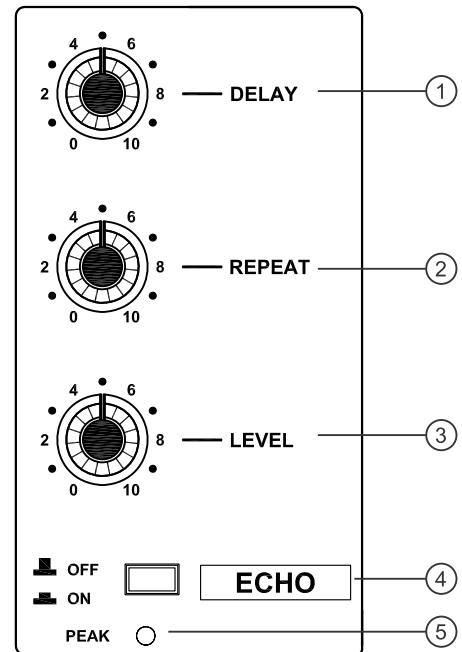

ECHO - Echo Effect is used to repeat the original sound many times to give multiple voice effect and is used for vocals. The Control settings for Echo are as shown in the diagram.

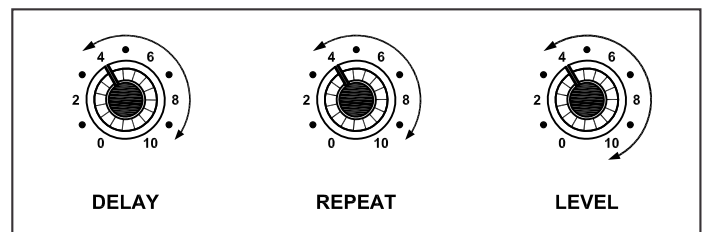

REVERB - Reverb is used for giving Hall Effect to the original sound as repeated reflecting sound raises overall level of the signal. This is also used for public announcement in Stadia and Open Air Performances. The Control settings for Reverb are as shown in the diagram.

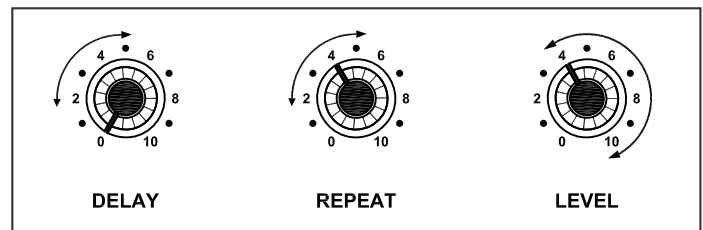

CHORUS - Chorus Effect is used by a singer to create an effect as if a Group is performing. The control settings for Chorus are as shown in the diagram.

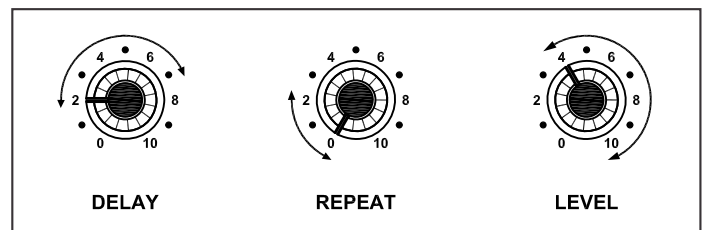

• The Tape Section

A 4 way RCA connector has been provided for connecting a Stereo Cassette Recorder to this audio mixer for Playback / Recording. Alternatively, a separate Stereo Cassette Recorder and a Stereo Cassette Player can be simultaneously connected for Recording and Playback respectively. This facility allows use of the other 7 input Channels for connecting input sources other than a Stereo Cassette Player.

1. RECORDING Outputs

The Left & Right RCA Sockets marked "REC" carry the stereo mix signal for connecting to the inputs of a stereo cassette recorder for Recording the program. These can also be connected to the Aux Input of an additional Monitor / Power Amplifier for driving them. The recording output level from AMX-812 is fixed (240mV) and is not affected by the settings of Master Level Controls and Tape Gain Controls.

2. PLAYBACK Inputs

The Left & Right RCA Sockets marked "PLAY" are for connecting to the Play Output of a stereo cassette player or the same cassette recorder being used for recording. The playback signals are routed to the main stereo mix of which the level is set by the Master level controls. However, the level of the playback mix into the main mix is set by the Gain Control. The input sensitivity of the Playback Inputs is 50mV. It can be adjusted from 50mV to 1V by the Gain Control to accept input signal from other sources such as a **CD Player, Electronic Keyboard, Drum Machine, Electronic Guitars** etc., to this mixer.

3. PLAY ON/OFF Switch

A Switch has been provided for switching OFF the playback music source connected to the mixer.

4. PLAY GAIN Control

A Gain Control is provided to set the Level of playback program to the overall program mix.

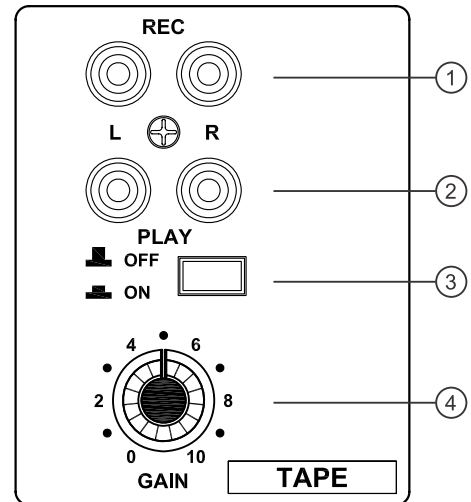

The Headphone Section

A Stereo Headphone Output is available through a 1/4" stereo jack for program monitoring.

Wiring:	Tip	Left Signal
	Ring	Right Signal
	Sleeve	Ground

Do not use Headphones of less than 8 Ohms Impedance.

1. GAIN Control

A Dual Gain Control has been provided for setting the level of the Headphone Output.

2. HEADPHONE Output

An Output has been provided through a 1/4" stereo jack for connecting a Headphone for monitoring the overall program.

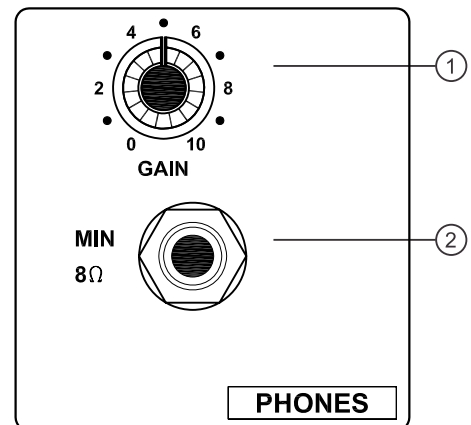

• Power Supply Section

1. AC FUSE 1 A, 240V

This protects the Mixer from damage in case of excessive current flow. In case the fuse blows, replace with another one of the same rating.

2. AC MAINS CORD

This is for connecting to AC mains supply. The Mixer is connected for 240V, 50Hz operation and will perform satisfactorily even when the AC Mains voltage drops to 200 V.

3. STANDBY 24V CAR BATTERY OPERATION

2 x 12V Car Batteries can be connected through the DC Plug (supplied as an accessory) to the DC Socket as shown in the diagram. In case of power failure, the Mixer continues to operate uninterrupted through the standby 24V DC Supply. Make sure the battery polarity is connected correctly.

- Use 2x12V car batteries exclusively for this equipment and do not connect any other equipment to these car batteries.
- Connect car batteries only through pre wired DC plug supplied with this equipment.
- Do not connect negative of car battery to earth terminal.
- This equipment operates on floating 24V DC.

4. EARTH TERMINAL

Before operating, the Mixer should be grounded by connecting a wire from this Earth Terminal to a water pipe or an electrical earth.

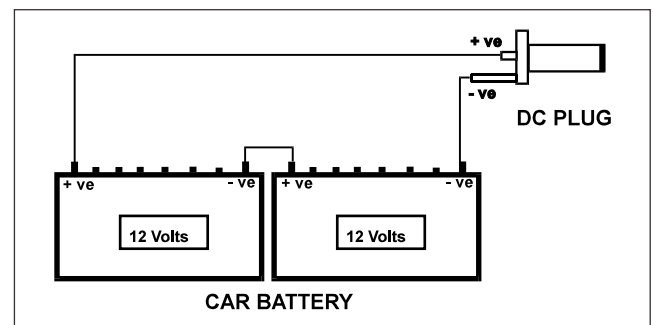
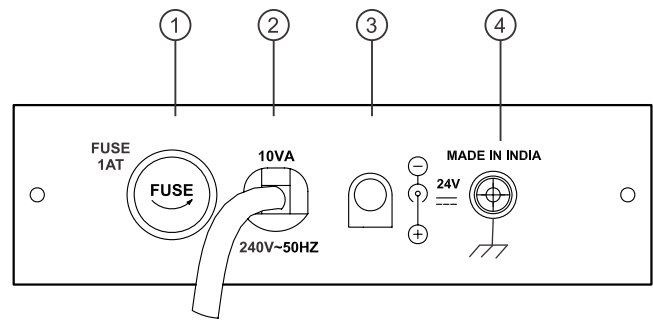

• Typical Applications

TYPICAL LIVE PERFORMANCE (STEREO MODE)

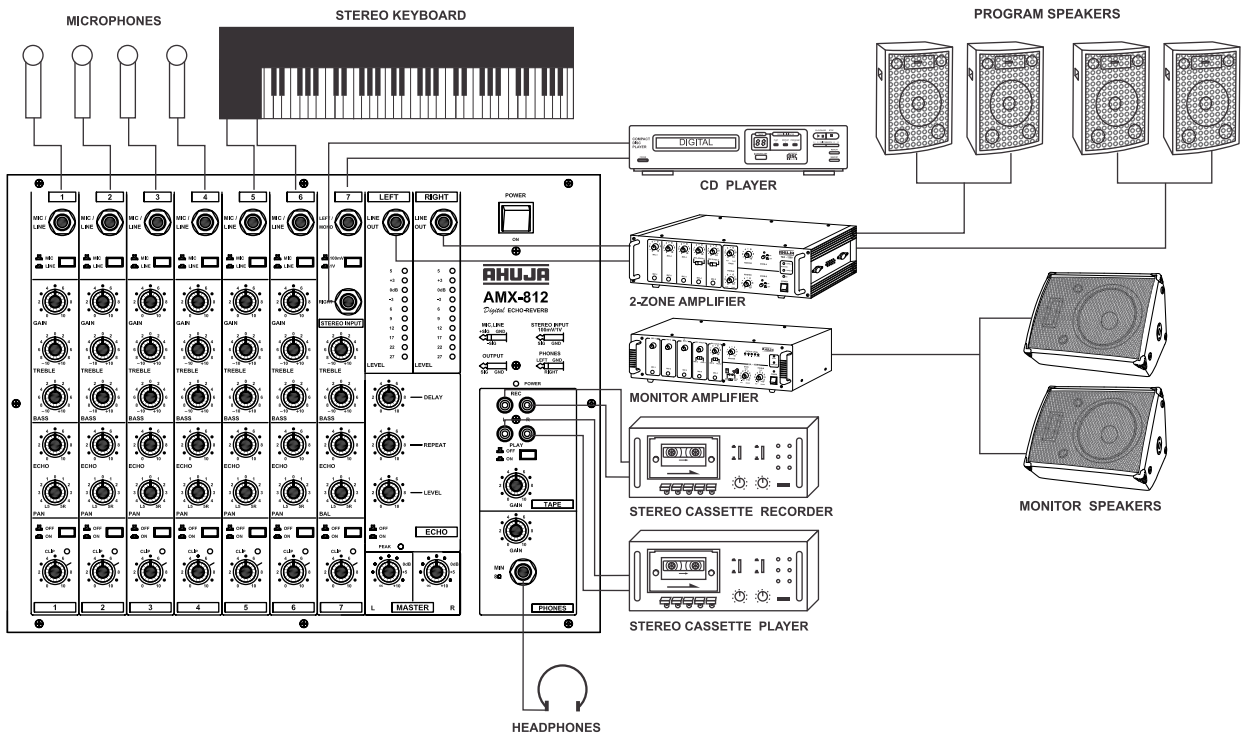

TYPICAL PA SOUND SYSTEM INSTALLATION

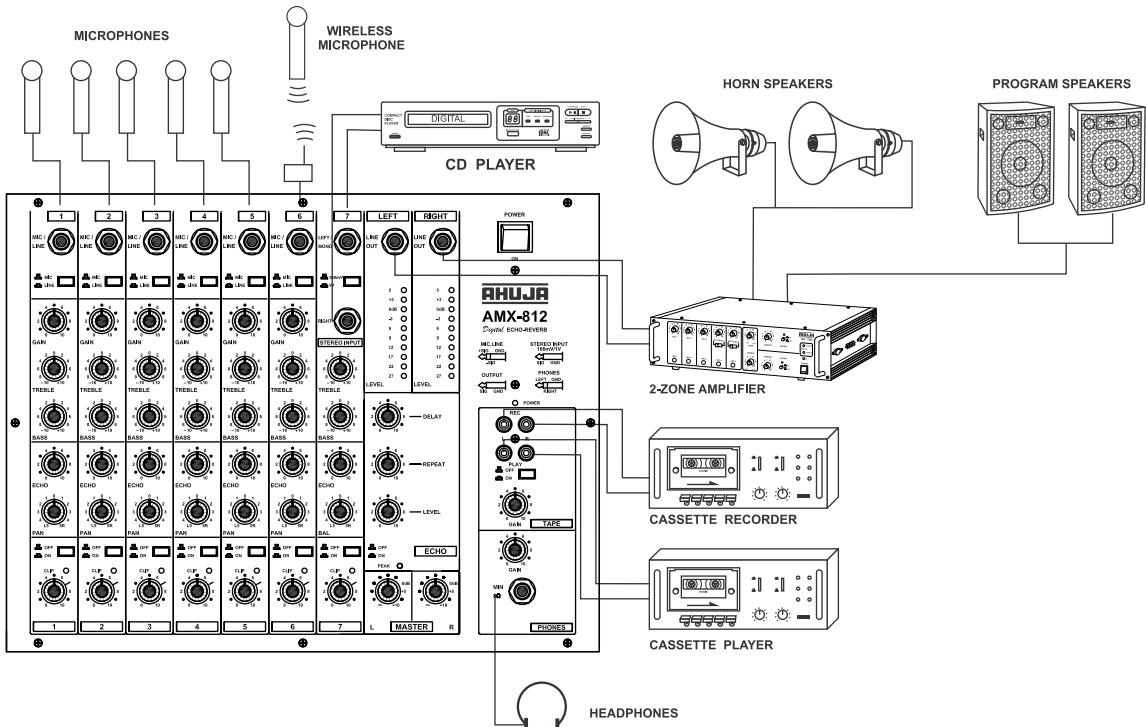

• Typical Applications

TYPICAL SUBMIXING SETUP

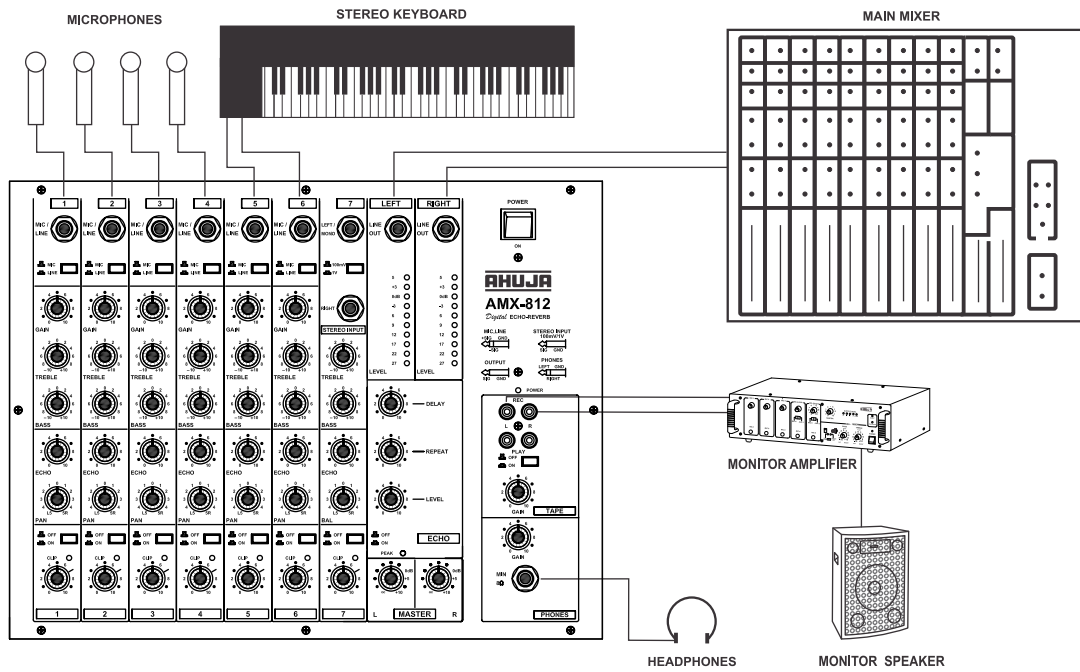

TYPICAL CONFERENCE / CONVENTION SETUP

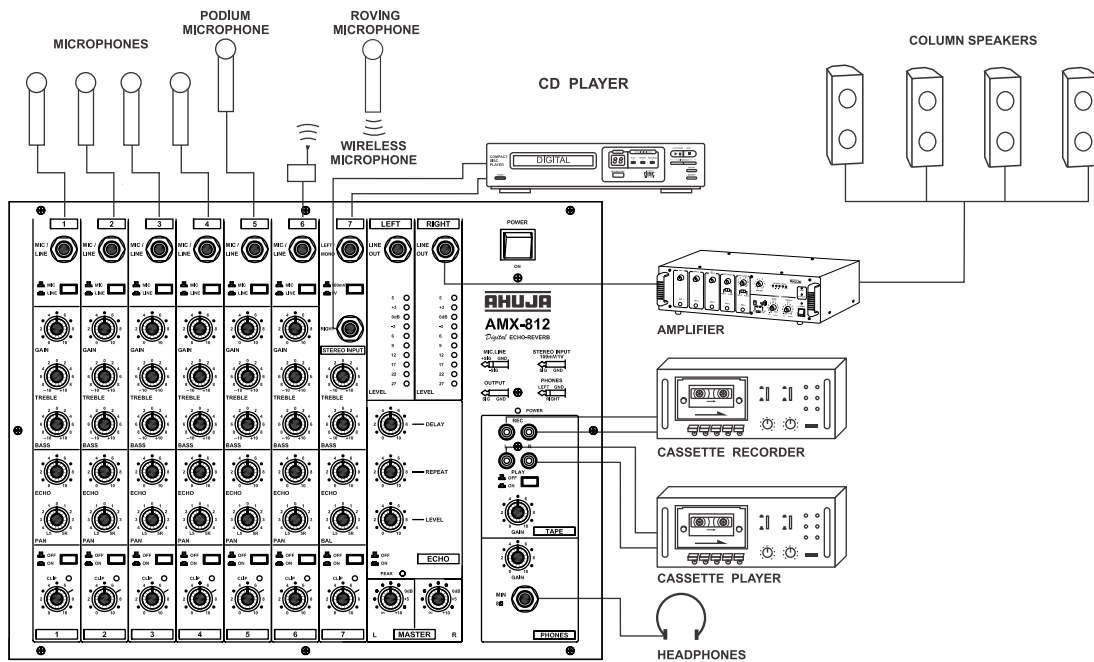

• Operation

1. Connect the microphones or line input sources like a CD player or Keyboard to the input jacks. Connect the output jacks to the desired equipment. Refer APPLICATIONS Section, page # 9, 10.
2. Keep all the rotary control settings of the mixer at '0' position.
3. Keep all the Channel Controls at '0' position and the Left/Right Master Controls at minimum position.
4. Keep all the channel ON/OFF switches and Tape Play Switch at OFF position.
5. Connect the AC Lead of the mixer to the nearest mains socket and connect the battery lead to car battery for interruption free operation. Refer Power Supply Section, page # 11.
6. Now switch 'On' the Mixer and the Input Sources.
7. Switch 'On' **Channel-1 only**, through its Channel On/Off Switch.
8. Connect the Headphones and position the Headphone Gain Control for a comfortable audible level.
9. Increase the Gain Control of **Channel-1 only** till the Clip LED lights up. Now decrease the gain control so that the Clip LED just flickers. This is the ideal setting of the gain control.
10. Set the Bass & Treble Controls to the desired levels. Changing the settings of the Bass & Treble Controls may affect the overall gain. Therefore the Gain Control should be subsequently adjusted to bring the Clip LED to the correct level.
11. Now move the Rotary Level control of **Channel-1 only** to position '7'.
12. In case **Echo Effect** is desired on **Channel-1** move the Echo Control of **Channel-1** to position '7'.
13. Switch 'On' the Echo Section and set the Echo Section (Delay, Repeat & Level Controls) for the desired effects. Refer to the Echo Section for the settings of the Delay, Repeat & Level Controls, page # 9.
14. Adjust the **Pan Control** to set the level of the signal in the Left & Right Outputs. Turning the control fully anti-clockwise will send the signal only to the Left Output of the mixer, and turning it clockwise will send it to the Right Output.
15. Once **Channel-1** is set, do not disturb the control settings of this channel. Then switch 'Off' this channel through the Channel On/Off Switch.
16. Repeat the above procedure for setting the remaining 5 channels.
17. Connect a Stereo source to **Channel-7**. Set the Bass & Treble Controls to the desired levels.
18. Move the Rotary Level control of **Channel-7** to position '7'.
19. In case Echo Effect is desired on **Channel-7** move the Echo control of this channel to position '7' and set the Echo section for the desired effects.
20. Adjust the Balance control for desired level of the signal in the Left & Right outputs.
21. After all the input channels have been set and switched 'On', the Peak LED of the Echo Section may start glowing continuously. Reduce the Echo Control level of individual channels and Echo Section simultaneously so that the Peak LED of the Echo Section goes below the flickering level.
22. After all the channels are set adjust the individual Channel level controls to obtain the desired MIX at the outputs.
23. Now adjust the Master level controls for desired output levels. However take care that the red LEDs of the LED Bargraph Array do not glow continuously. Refer Output Section, page # 8.
24. For Recording and Playback refer to the Tape Section, page # 10.

PLUGS WIRING

The wiring for various jacks (Input & Output Devices) is as shown below:

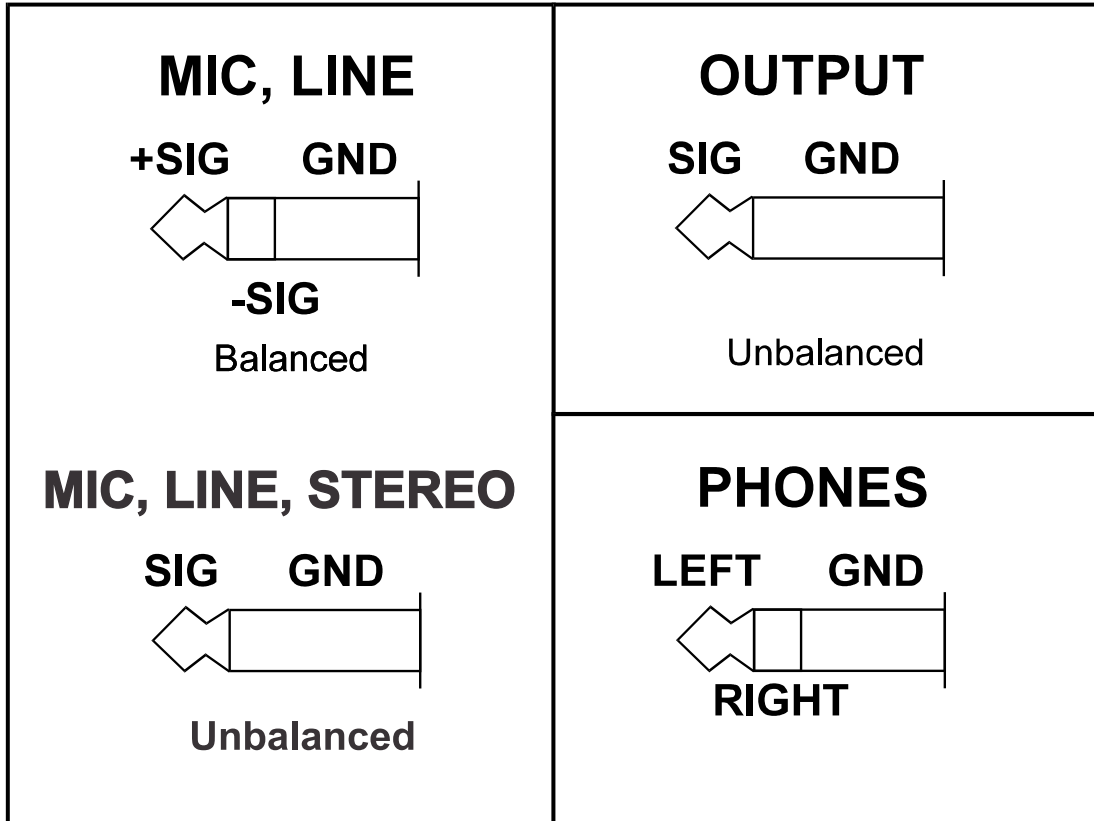

• Specifications

MIC INPUT Impedance / Gain	2K ohms / 62 dB
LINE INPUT Impedance / Gain	20K ohms Balanced / 42 dB 10K ohms Unbalanced / 42 dB
STEREO INPUT (L/MONO & R) Impedance / Sensitivity	10K ohms Unbalanced / 100mV 68K ohms Unbalanced / 1V
THD	< 0.08 %
FREQUENCY RESPONSE L/R Line Output	30 Hz - 20 KHz (+0, -1 dB)
EQUALIZATION Bass / Treble	± 12 dB at 100 Hz / 10KHz
CLIP LED INDICATION	4 dB prior to true clip
OUTPUTS Line Output L/R Nominal/Max. Level Impedance	0 dBm / +17 dBm (775mV / 5.5 V) 600 ohms
MAXIMUM GAIN Mic input to Line Outputs Line input to Line Outputs	76 dB 55 dB
TAPE Record Output Playback Input	240mV RMS / 600 ohms 50mV - 1V RMS/1K ohms, variable thru' GAIN control
HEADPHONE Output	150 mV at 8 ohms, THD < 1%
ECHO Distortion Echo System Delay Time	< 1% Digital Signal Processing 20 ms to 600 ms
S / N RATIO Line Output Level	>70 dB (0dBm, 0.775V)
POWER SUPPLY	AC: 240V, 50Hz DC: 24V
PROTECTIONS	AC: 1Amp. 250V (T 1A L)
DIMENSIONS	W423 x H93 x D302mm
NET WEIGHT	5 kg

Design and Specifications are subject to change without notice owing to continuous product up-gradation. Technical specifications are subject to production tolerances.
We cannot be held responsible for printing errors, should they occur. **TRUSOUND** is a registered trademark of Ahuja Radios in India and other countries.
© Copyright Ahuja Radios, 2013. All rights reserved. Any unauthorized reproduction or use of logos, images or design elements is strictly prohibited by law.
No part of this compilation may be reproduced in any manner or translated without written permission.

TRUSOUND PVT. LTD. • C-89, Sector IV, Noida, Gautam Budh Nagar-201 301 (UP)
Regd. Office : 125E, Okhla Industrial Estate, New Delhi-110 020
Tel.: +91-120-4665665 Fax : +91-120-4665621
E-mail: trusoundsupport@airtelmail.in

E. & O. E. 0K/09/13