

RAVEN
by SilverStone

RAVEN SERIES

Reinvent the future

5

Special Features

- Signature RAVEN styling touches
- Revolutionary 90 degree motherboard mounting from RAVEN RV01
- Breakthrough 5.25 inch bay-free design for unprecedented power to size ratio
- Two Air Penetrator AP fans included for great performance and quietness
- Positive air pressure design for excellent cooling/quietness and dust-prevention
- Quick-release latch for fast side panel removal
- Front access to main filter for easy maintenance
- Support for various liquid cooling radiator sizes



HEADQUARTERS

12F., NO.168, Jiankang Rd., Zhonghe Dist.,
New Taipei City 235, Taiwan R.O.C.
Tel: +886-2-8228-1238
Fax: +886-2-8228-7123

USA

13626 Monte Vista Ave. Unit A, Chino,
CA 91710, USA
Tel: +1-909-465-9596
Fax: +1-909-465-9596

EUROPE

Brandstücken 43, D-22549 Hamburg
Germany
Tel: +49-40-675931-0
Fax: +49-40-675931-66

Model: SST-RV05B
SST-RV05B-W

www.silverstonetek.com

Introduction

Reinvent the future **RV05**

The RAVEN RV05, the fifth edition in the exciting RAVEN enthusiasts chassis series continues the tradition of breaking and evolving the standards of desktop PC design. With a bold move that sees the removal of all 5.25" drive bays, the RAVEN team engineers again saw the opportunity to re-utilize the 90 degree rotated design. Previous RAVEN models with 90 degree layout often had to compromise on space efficiency due to fixed length of the motherboard in rotated orientation. The elimination of 5.25" bays solves this issue naturally and enables RV05 to be even more balanced in terms of design than if the same were done to a traditionally-layout case.

With most of the wasted space eliminated from RV05, engineers were thus able to better optimize the case for the most important performance-affecting components such as CPU and GPUs. The result is an expertly-engineered ATX chassis that is just as capable in terms of compute power and heat dissipation as the first RAVEN chassis, the RV01, but in half the size. Equipped with latest revision Air Penetrator fans that include three speed switches and modern touches such as externally removable filters and tool-less panels, the RV05 has everything that PC enthusiasts could wish for in a compact, high performance computer case that is not only cool and quiet, but also easy to build and maintain. For those not wanting to constantly step up in case size to obtain top-level performance, the RAVEN RV05 is the perfect solution and it may also represent a glimpse into the future of mainstream enthusiasts PC design.

Features Photos



Revolutionary 90 degrees motherboard mounting enables stack effect for natural heat convection



Slim slot-loading optical drive slot



Positive air pressure design with front-accessible main filter for class leading dust reduction



Includes two Air Penetrator 180mm fans for superb performance and quietness



Supports two easy access drive bays with thumb screw design



Two 2.5" SSD/HDD slots on the backplate

Specifications

Model	SST-RV05B (black) SST-RV05B-W (black + window)	Expansion Slot	7
Material	Plastic outer shell, steel body	Front I/O Port	USB 3.0 x 2 / audio x 1 / MIC x 1
Motherboard	SSI-CEB, ATX, Micro-ATX	Power Supply	Optional PS2 (ATX)
Drive Bay	Exposed Slim slot-loading optical x 1	Expansion Card	Compatible with 12.3" long, width restriction – 6.57"
	Internal 3.5" x 2, 2.5" x 2	Limitation of CPU cooler	162mm
Cooling System	Bottom 180mm AP fan x 2, 600/900/1200rpm, 17/25/34dBA	Dimension	242mm (W) x 529mm (H) x 498mm (D)
	Top Downward compatible with 120mm fan x 3, or 140mm fan x 2 120mm fan slot x 1		

- 1** Revolutionary 90 degrees motherboard mounting enables stack effect for natural heat convection
- 2** Independent PSU intake vent prevents waste heat circulation
- 3** Supports up to SSI-CEB motherboard
- 4** Two 2.5" SSD/HDD slots on the backplate
- 5** Supports two easy access drive bays with thumb screw design
- 6** Top-mounted stealth I/O ports include microphone, audio and two USB 3.0 ports
- 7** All black one-piece front panel inherits signature RAVEN styling touches
- 8** Slim slot-loading optical drive slot
- 9** Support for various liquid cooling radiator configurations
- 10** Positive air pressure design with front-accessible main filter for class leading dust reduction
- 11** Top 120mm fan slot completes overall airflow and supports AIO liquid cooler
- 12** Includes two Air Penetrator 180mm fans for superb performance and quietness

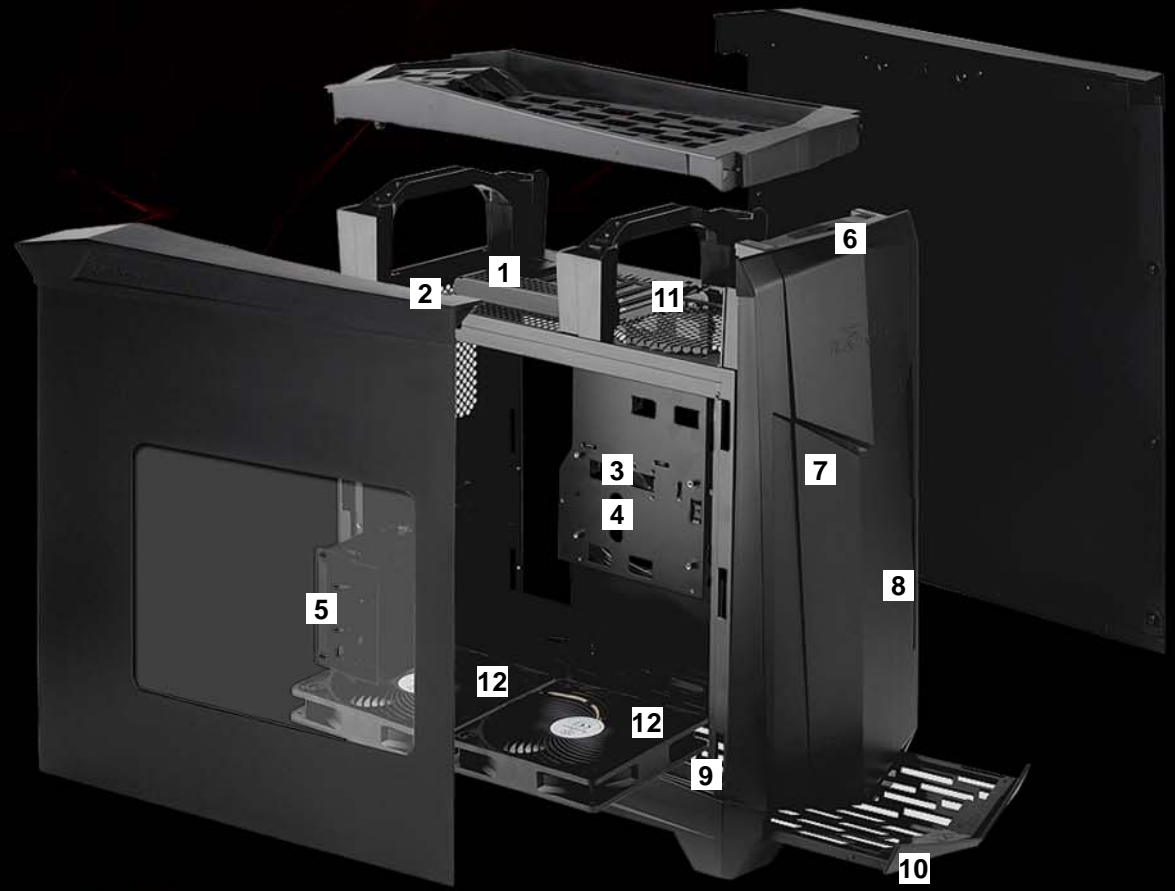

Recommendations



ST1200-G Evolution
Class-leading single +12V rail with 100A



AP123
Mixed fan blade design for noise reduction



HE01
Six soldered heat-pipe, copper base and aluminum fins ensuring the best thermal conducting efficiency.



SOB02/SOD02
Slot loading design for elegant integration



CP07
SATA III cable with non-scratch locking mechanism and 180° connector



TD02/03
Patented brazing fins radiator increase cooling efficiency by 40%